



THE MINIMATOR

Compaction of used beverage containers

PET-bottles

- Aluminum cans
- Steel cans T
- Tetra pack
- Glass
- Mixed materials



Nordic
Recycling
Systems



The Minimator is available in a standalone configuration and can be easily integrated into various applications, including counting lines and reverse vending machines (RVMs) in deposit markets, or other industrial applications requiring compaction of different container types.

[Read more on our website](#)

- PET-bottles
- Aluminum cans
- Steel cans T
- Tetra pack
- Glass
- Mixed materials
- Compaction ratio 1:2 -1:4
- Capacity of 1300 -1600 pcs/m
- 0/60Hz
- 4/5/11 kw
- 115/208/230/400 VAC
- Extreme lifetime
- Easy serviceable
- External control/signals
- Worldwide shipping
- CE/ULC/UL
- Standalone or integration

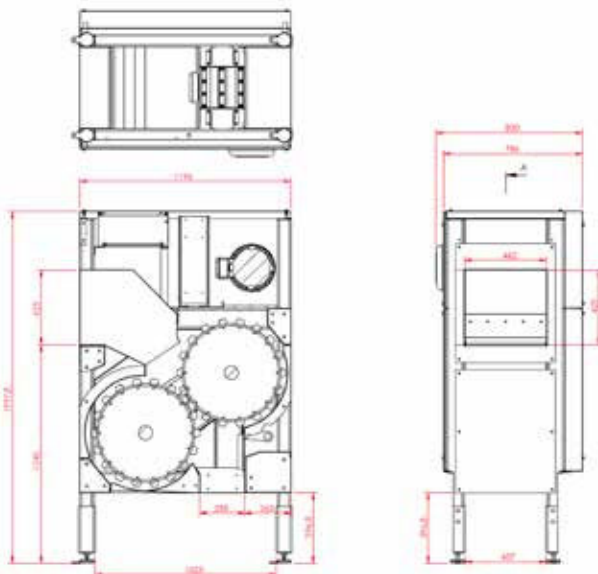



Long lifetime with Changeable tools

Designed for longevity and low operational costs, our Minimator machines have compacted several hundred million units worldwide. Compacted materials are handled using traditional conveyors or our own developed and integrated air conveying systems, which are very clean and flexible in terms of labels- and liquids spillage.



Discharge via conveyor or air conveying system

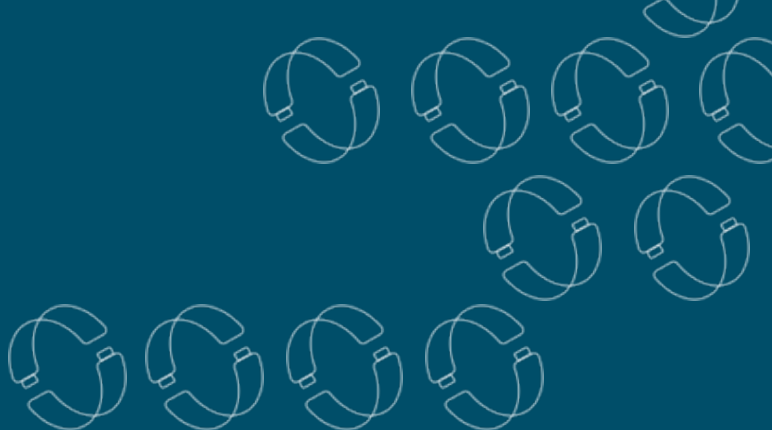

MADE IN SCANDINAVIA

FOR SCANDINAVIAN CONDITIONS

NORDIC RECYCLING SYSTEMS A/S

VARIG ALLE 1

4180 SORØ

DENMARK

+47 416 38 710

HELLO@NORDIC-RECYCLING.COM

WWW.NORDIC-RECYCLING.COM



Nordic
Recycling
Systems